

ZINEX MINING CORP

U5
DRILL

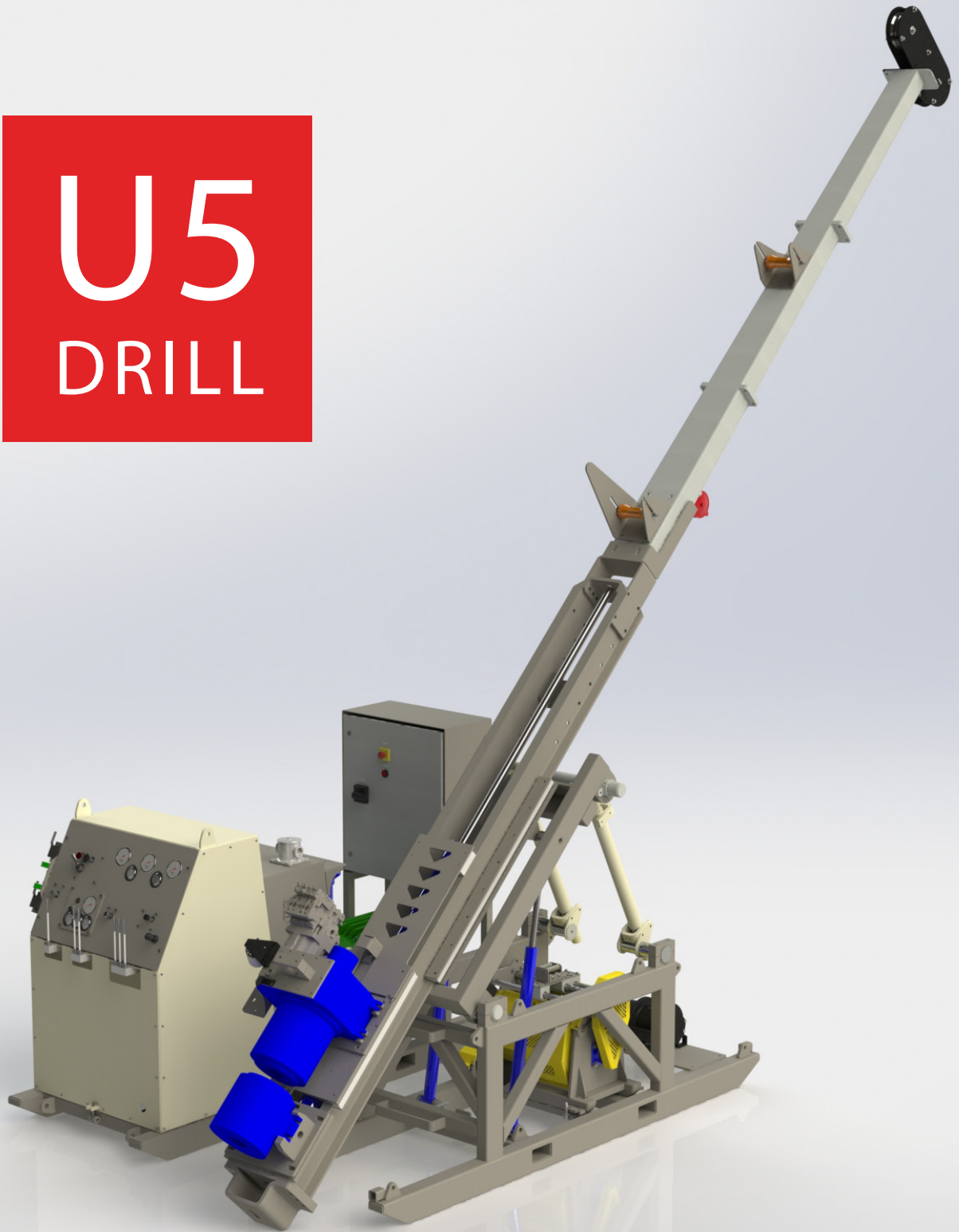

HIGH PERFORMANCE DIAMOND DRILLS FOR THE EXPLORATION INDUSTRY

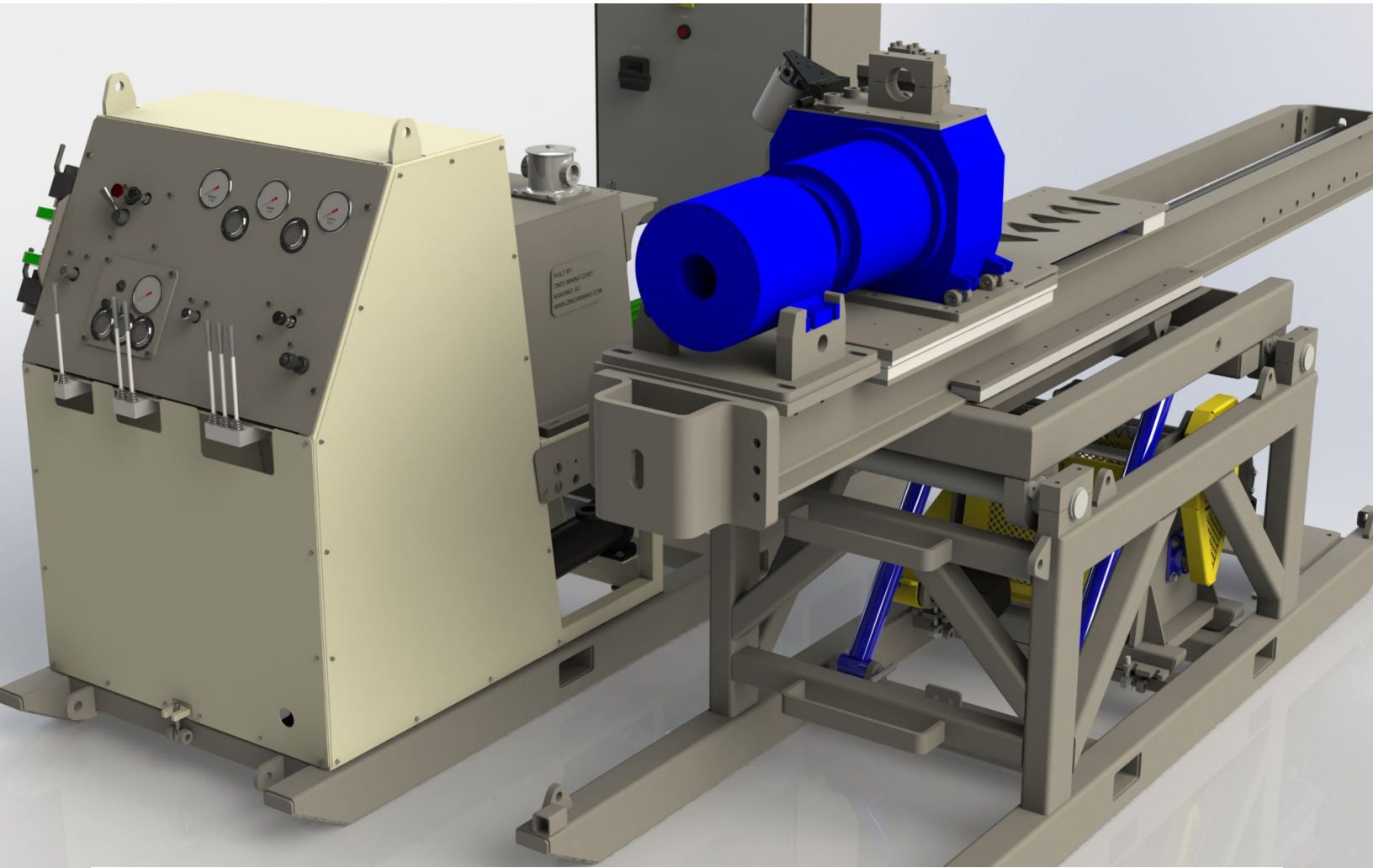

The U5 is an underground version of the well known A5. Having the same hydraulic power module and controls it allows contractors to maintain a common fleet of drills which crews are familiar with and parts are interchangeable. This in turn reduces training time and cost of inventory for spare and consumable parts

The U5 was designed by our team assuring simplicity while upholding our exceptional standards of strength and durability. All of our parts are fabricated in batches of 10 allowing us to keep our prices competitive and quality consistent.

All of our Hydraulic parts are locally supplied and of the highest quality. Every drill is set up the same and tested thoroughly before it leaves our manufacturing facility.

This underground drill can also be used on surface having a 5.5' stroke and has become popular as a track and truck mounted unit having mast dump capabilities. The main skid frame accepts a diesel engine in place of the electric motor. An A5 surface tower can be installed to allow for pulling of 10'/3m tubes.

U5 TECHNICAL DRILL SPECS

MODEL:	ZINEX U5
WEIGHT:	7500LBS
DEPTH CAPACITY H:	1000M
MOTOR:	BALDOR 150HP
DRILL HEAD:	H-CHUCK/P-CHUCK
FOOT CLAMP:	H-CLAMP/P-CLAMP
SYNCHRONIZED ROD HANDLING:	RODS IN/RODS OUT MODE
RPM:	1500RPM
ROTATIONAL TORQUE:	350 FT LBS @ 1610 RPM, 1750 FT LBS @ 342 RPM HIGH GEAR 625 FT LBS @ 894 RPM, 3145 FT LBS @ 190 RPM LOW GEAR
DRILL HEAD/ CHUCK WEIGHT CAPACITY:	26,000 LBS
ROTATION MOTOR:	VARIABLE DISPLACEMENT 160 CC
FEED STROKE:	66"
MAXIMUM PULL BACK:	45,720 LBS PULLBACK
MAXIMUM FEED FORCE:	30,480 LBS
WINCH:	LEVELWIND CAPACITY 3500FT
HOIST WINCH:	ROTZLER 70FT CAPACITY
HYDRAULIC TANK CAPACITY:	200 LITERS
HYDRAULIC COOLER:	WATER

INCLUDED ITEMS:	MUD TANK MUD MIXER
------------------------	-----------------------

OPTIONAL ITEMS:	SELF PROPELLED GUARDING WATER PUMP
------------------------	--

DESCRIPTION	
1	CUSTOM DOUBLE SHEAVE WHEEL
2	REINFORCED ALUMINUM STINGER
3	SEGMENTED STINGER
4	66" STROKE CYLINDER
5	MAST DUMP FEED FRAME
6	CARBIDE CLAMP STIFF LEGS
7	ROD HOIST WINCH
8	LEVELWIND WINCH
9	ABILITY TO DRILL UP + DOWN
10	200L HYD. TANK
11	HIGH OUTPUT ELECTRIC MOTOR
12	ELECTRIC CONTROL PANEL

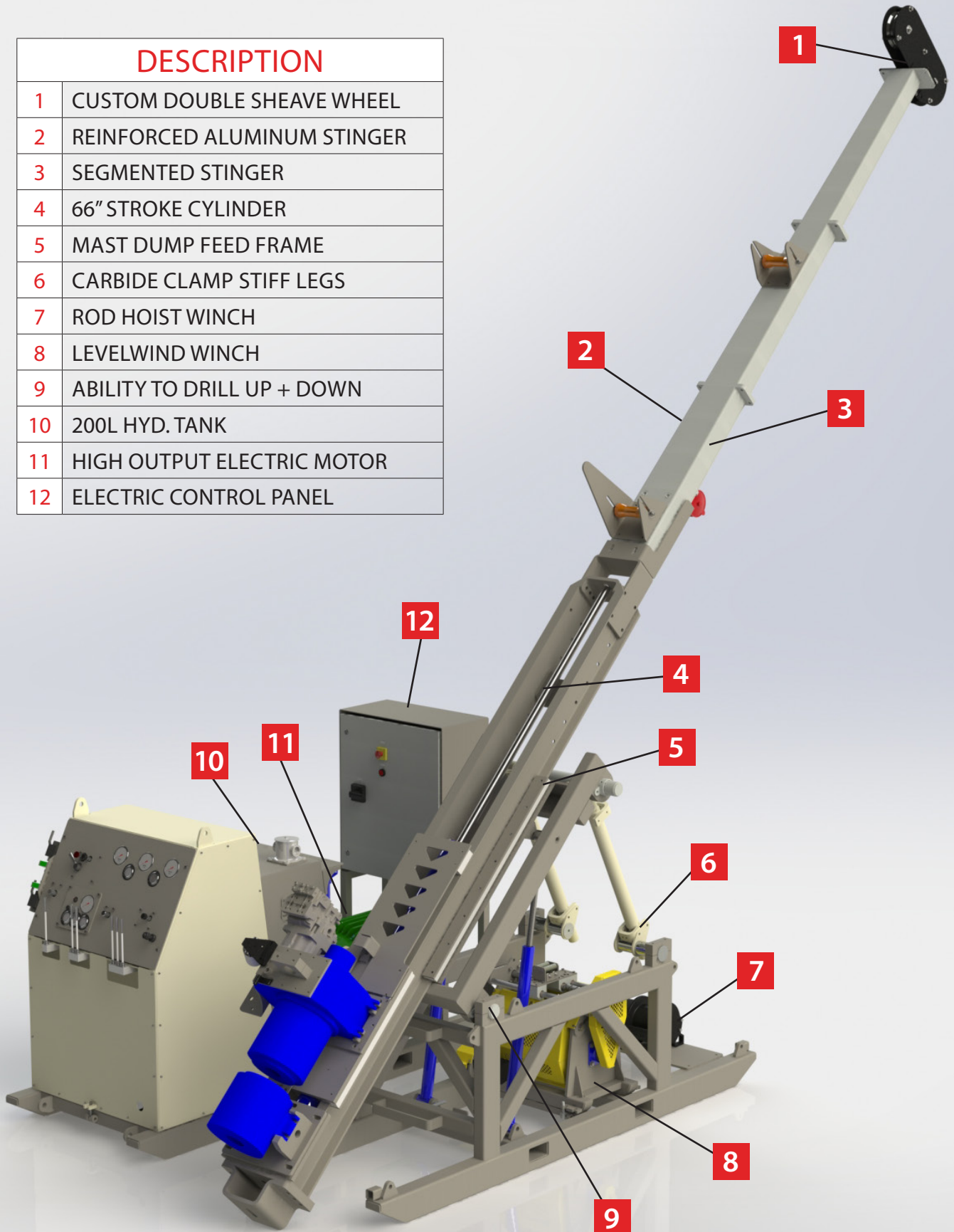

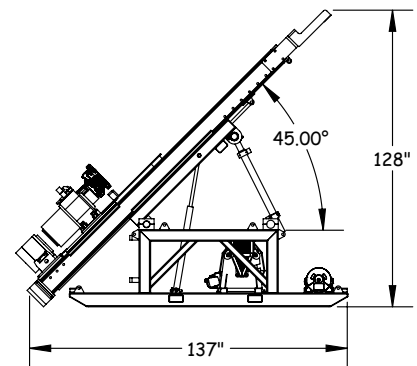
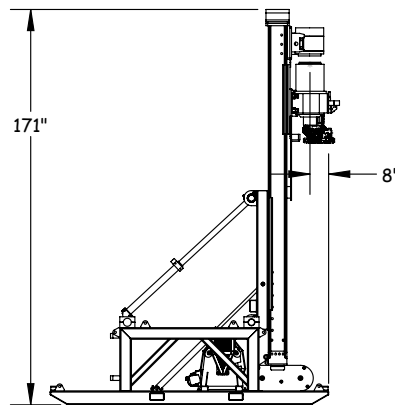
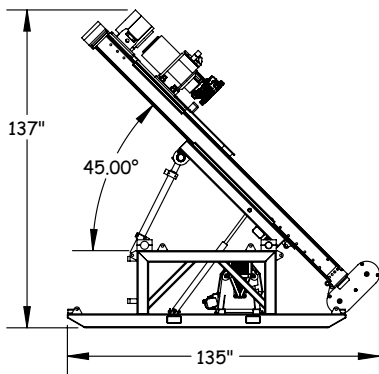
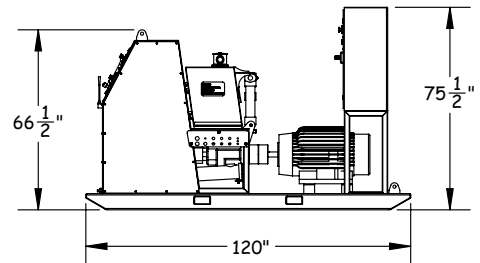
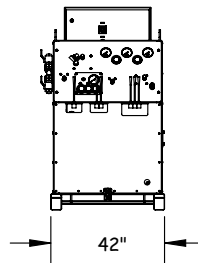
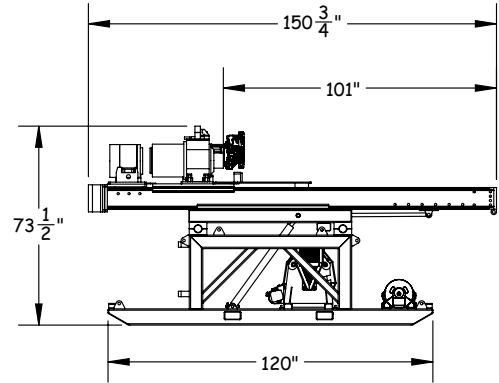
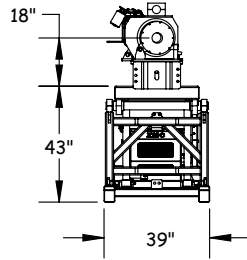
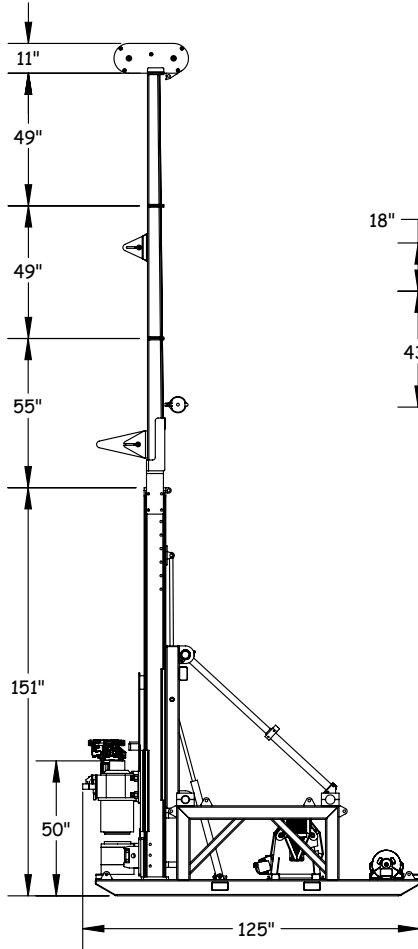

ZINEX MINING CORP



ZINEX MINING CORPORATION

Phone: 604-932-1211

Email: sales@zinexmining.com

Website: www.zinexmining.com

HIGH PERFORMANCE DIAMOND DRILLS FOR THE EXPLORATION INDUSTRY